

An RMRAC Control for Permanent Magnet Synchronous Motor Based on Statistical Mode Interpretation

Hong-Zhe Jin, Hyun-Seok Son, Hoon Lim and Jang-Myung Lee

Department of Electronics Engineering, Pusan National University
San 30 Jangjeon-dong Kumjeong-Ku, Busan, 609-735, Korea
(Tel : 82-51-510-2378; Fax : 82-51-515-5190)

(hit_pnu@pusan.ac.kr, yankiss@pusan.ac.kr, aptldk0229@pusan.ac.kr, jmlee@pusan.ac.kr)

Abstract: A simple RMRAC (Robust Model Reference Adaptive Control) scheme for the PMSM (Permanent Magnet Synchronous Motor) is propose in the synchronous frame. A current control of PMSM is the most inner loop of electromechanical driving systems and it requires a fast and simple control law to play a foundation role in the hierarchy's control loop. In the proposed synchronous current model, the input signal is composed a calculated voltage by adaptive laws and system disturbances. The gains of feed-forward and feedback controllers are estimated by the proposed *e-modification* method respectively, where the system disturbances are assumed as filtered current tracking errors. After the estimation of the system disturbances from the tracking errors, the corresponding voltage is fed forward to control input to compensate for the disturbances. The proposed method is robust against high frequency disturbances and has a fast dynamic response for time varying reference current trajectory. It also shows a good real-time performance due to it's simplicity of control structure. Through real experiments, efficiency of the proposed method is verified.

Keywords: RMRAC, *e-modification*, feed-forward compensation, statistical model, high frequency disturbances.

I. INTRODUCTION

For object transferring robots and mechanical systems in various industries, the trajectory control is generally required. Necessary control torque is calculated based on the dynamic model of mechanical system and motors for the precise trajectory control. For an example, the computed torque is implemented by an indirect vector control method for a three phase PMSM (Permanent Magnet Synchronous Motor). The control performance is directly related to the current control strategy of the motor.

P-I (Proportional-Integral) controller is very popular for the current control in industries [1, 2]. The P-I controller improves steady state error characteristics for a fixed reference current. However it is not suitable for a system where a precise and fast trajectory tracking are with a fast changing reference current. On the contrary, the hysteresis current controller does not show a good steady state performance. Predictive current controller is very sensitive to motor parameters which can be changed un-expectedly by the environmental conditions [3, 4].

This paper proposes a new current control algorithm, RMRAC. It is designed as a decoupled control structure by handling the *d* and *q* axes back *e.m.f* in the synchronized coordinate system as disturbances.

II. Statistical Current Model Representation

Current plant model of PMSM amateur in synchronization coordinates *d* and *q* axes can be represented as [5].

$$\dot{i}_d = -\frac{R}{L_d}i_d + \frac{1}{L_d}(u_d + L_q P i_q \omega - v_d) \quad (1a)$$

$$\dot{i}_q = -\frac{R}{L_q}i_q + \frac{1}{L_q}(u_q - L_d P i_d \cdot \omega - P \lambda \omega - v_q) \quad (1b)$$

In the conventional approach [5], disturbance v_d and v_q in Eq. (1) have been ignored and the coupled back *e.m.f* terms are incorporated to *d-q* axis current state model. In this research, decoupled *d-q* current state model is proposed by defining a system disturbance as the summation of the back *e.m.f* and the external disturbance. That is, the back *e.m.f* is considered as an internal disturbance. From Eq. (1), system disturbance is defined as follows:

$$v_{ds} = v_d - L_q \cdot P \cdot i_q \cdot \omega \quad (2a)$$

$$v_{qs} = L_d \cdot P \cdot i_d \cdot \omega + P \cdot \lambda \cdot \omega + v_q \quad (2b)$$

To represent the current model regardless of the *d*-axis and *q*-axis, $R/L_d = a_d$ and $1/L_d = b_d$ are defined for *d*-axis and $R/L_q = a_q$ are defined for *q*-axis.

Now from Eqs(1) and (2), the current model can be represented as

$$i_l = \frac{b_l}{s+a_l} \cdot u_l - \frac{b_l}{s+a_l} \cdot v_{lb} \quad (3)$$

where l represents either d or q and s is Laplace operator. The system disturbances, v_{lb} is directly related to drift of motor parameters, back *e.m.f.*, change of load to the rotor axis, and error in flux angle measurement of permanent magnet. This system disturbance affects to the tracking error performance of current control since it is very difficult to measure and is it has time varying characteristics. That is, the tracking error in current control is an unknown function of the system disturbance. In stochastic point of view, tracking error can be handled as a noise with a certain distribution.

Using this assumption, the STR (Self Tuning Regulator) adaptive control strategy can commonly be founded from existing literature [6]. In real application, precise modeling of functional relationship between the tracking error and the system disturbance is impossible. However a frequency band which corresponds to high energy band of disturbance can be extracted precisely from the frequency band of tracking error.

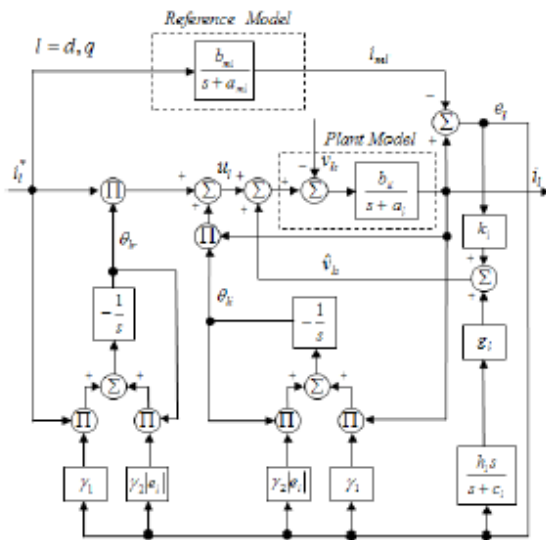

Fig. 1. Proposed RMRAC current tracking controller

In summary, the system disturbance is obtained from the tracking error and fed forward to the control input of RMRAC (refer to Fig. 1).

III. RMRAC Controller Design

1. Reference Model of Current Tracking Controller

Response characteristics of current controller against time varying reference current, that is reference model, can be defined as

$$i_{ml} = \frac{b_{ml}}{s+a_{ml}} \cdot i_l^* \quad (4)$$

where i_l^* represents a desired reference current trajectory of either d -axis or q -axis, i_{ml} is the output of corresponding reference model, a_{ml} is a parameter to determine the response of the reference model against reference time varying current trajectory, and b_{ml} is the high frequency gain. With the change of these parameters, response characteristics of control system and robustness against disturbances are adjusted.

2. RMRAC Control Input

The control input of RMRAC for reference model tracking is modeled as

$$u_l = \theta_{lr}(t) \cdot i_l^* + \theta_{ll}(t) \cdot i_l + \hat{v}_{lb} \quad (5)$$

Where θ_{lr} represents a feed forward time varying compensation coefficient and θ_{ll} is a feedback time varying compensation coefficient. The coefficient values are updated by the e -parameter estimation method which will be described in the following subsection. \hat{v}_{lb} is estimated by the disturbance observer showed in Fig. 1. This control structure provides a perfect decoupling of d - q axis through the disturbance observer to compensate system disturbances.

3. Estimation of Parameter of Controller using e -modification Method

First of all, parameter tracking error of the controller are defined: φ_l is defined as an error between the feed forward compensation coefficient, θ_{lr} , and the corresponding real parameter value, θ_{lr}^* , and ψ_l is defined as the error between the feedback compensation coefficient, θ_{ll} , and the corresponding real parameter, θ_{ll}^* . The real values of the feed forward compensation coefficient and the feedback compensation coefficient are assumed to be constant and represented as follows:

$$\theta_{lr}^* = b_{ml} / b_l \quad (6)$$

$$\theta_{ll}^* = (a_l - a_{ml}) / b_l \quad (7)$$

Where the parameters are unknown since PMSM parameters are incorporated in themselves.

For the parameter estimation, *Gradient* method [7] is introduced. However its output is diverged by the integral operation of the error and disturbances in many cases. In practice, several alternative estimation techniques are proposed based on the *Dead None* approach [8, 9]. In the techniques, the *Gradient* algorithm is performed until the tracking error comes into the preset bound named as *Dead Zone*. This method shows a good real time performance in parameter adaptation speed and stability. However, the tracking error against time varying reference trajectory is very sensitive to the pre-determined threshold value. That is, when the threshold value is small, the output does not converge on account of frequent integral operations and disturbance. When the threshold value is large, the tracking performance becomes poor even though the output converges. Therefore, in this paper, for both of stability and performance, *e-modification* estimation technique [10] is adopted.

The controller parameters are adapted by the following rules:

$$\dot{\phi}_{lr} = -\gamma_1 \cdot \text{sgn}(b_l) \cdot e_l \cdot i_l^* - \gamma_2 \cdot |e_l| \cdot \theta_{lr} \quad (8)$$

$$\dot{\psi}_{ll} = -\gamma_1 \cdot \text{sgn}(b_l) \cdot e_l \cdot i_l - \gamma_2 \cdot |e_l| \cdot \theta_{ll} \quad (9)$$

Where γ_1 and γ_2 represent parameter adaptation gains, respectively.

V. Efficiency Verification of the Proposed Method

From the experiments, the characteristics of tracking error and response current of the proposed method are analyzed to compare to the characteristics of the conventional *e-modification* method [10] in terms of tracking performance.

Motor specifications are given as follows: rated speed: 3000 r/min; stator resistance $R = 16.571\Omega$; stator inductance: $L_d = 0.296H$, $L_q = 0.378H$; flux: 1.32Wb.turn; number of pole pairs $P = 4$.

Figure 2 shows block diagram of the experimental system for the algorithm verification. The main algorithm is processed by Microchip dsPIC30F6010A DSP (Digital Signal Processor). The control cycle is set as 2×10^{-4} . PWM (Pulse Width Modulation) Period is set as 4×10^{-5} s. Therefore every five PWM cycles, input voltage of u_i is updated. The encoder for PMSM

for PMSM has 2048 pulses for a revolution. The resolution is improved to 8192 pulse by the built-in fourfold pulse modulation at the signal processor using the encoder pulse through QEI (Quadrature Encoder Interface). The one pulse of encoder corresponds to 8×10^{-4} rad. The three phase currents of PMSM are fed to the input port of AD converter as voltage through the hall-effect current transducer.

Three-phase voltage source and PWM inverter are designed by Mitsubishi IGBTs (Insulated Gate Bipolar Transistors) (Model: PM300CLA060, 20KW) to drive PMSM. Through the Clark-transform, the currents i_α , i_β in the fixed frame are calculated, and the currents i_d and i_q in the synchronous frame are obtained by the Park-transform. The voltage calculated in the synchronous frame, u_d and u_q , are transformed to the voltage in the fixed frame, u_α and u_β , by the inverse Park-transform. Finally the voltages, u_α and u_β , are used for the inputs of SVM (Space Vector Modulation) algorithm to calculate the three phase input voltage, u_a , u_b , u_c to drive the PMSM [11]. The flux location of PMSM, θ_f , is calculated precisely from the slip angle compensation algorithm based on the current model in the synchronous frame [12].

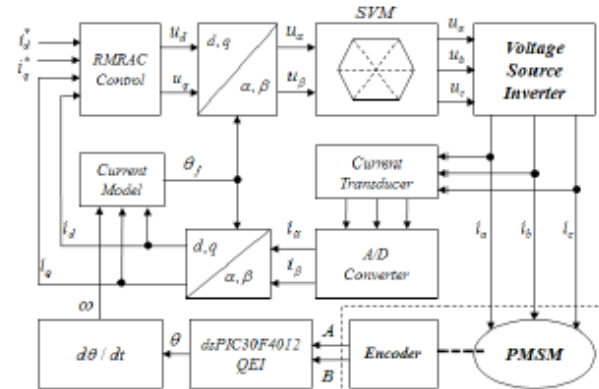

Fig. 2. Block diagram of the experimental system

Figure 3(a) and 3(b) show the current tracking performance without the disturbance observer and with the disturbance observer, respectively. The reference model parameters are set as $a_{ml} = 1000$ and $b_{ml} = 1000$. The adaptation gains are $\gamma_1 = 2000$ and $\gamma_2 = 0.1$. In figures, the solid line shows the real current value while the dotted line shows the reference current.

The average tracking error without the disturbance observer is 0.45A which is reduce to 0.125A by

applying the disturbance observer. The tracking error exists mainly in the d -axis while the q -axis is relatively insensitive to the disturbance. Notice that the d -axis real current deviates 0.8A from the reference current in Fig. 3(a), while the d -axis real current deviates only 0.25A from the reference current in Fig. 3(b). This implies that the disturbance observer has explicit suppression effects against the back $e.m.f$ induced by the current and external disturbance.

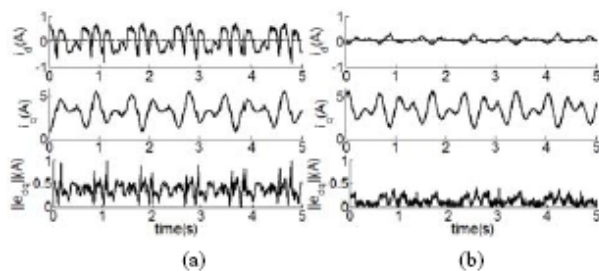

Fig. 3. Current tracking performance. (a) Without disturbance observer. (b) With disturbance observer. Parameters of disturbance observer: $c_d = c_q = 1000$, $h_d = h_q = 1200$, $k_d = k_q = 10$, $g_d = g_q = 1$.

Acknowledgements: This work was supported by the Korea Science and Engineering Foundation (KOSEF) grant funded by the Korea government (MOST) (No. R01-2007-000-10171)

VI. CONCLUSION

This paper defines a new stochastic current model of PMSM in synchronous d - q reference frame including system disturbances. In the control system, the characteristics of that the tracking error is a certain function of disturbances is used and inversely, assuming that the system disturbance is a filtered current tracking errors. Based on above hypothesis, a simple disturbance observer has been designed and implemented. The output of disturbance observer is fed forward to the control input computed by the conventional MRAC (Model Reference Adaptive Control). To guarantee the stability in parameter estimation, e -modification method is adopted. By the experimental result, effectiveness of this algorithm has been proved at extreme disturbance conditions. From the results of experiments, it is concluded that disturbance in low speed operation and instantaneous change of current cause the temporary error, which needs to be eliminated by the future research of disturbance observer with optimal control structure design and disturbance signal modeling based on spectrum analysis theory.

REFERENCES

- [1] Kiyoshi Ohishi, *Member, IEEE*, Emiko Hayasaka, Tetsuaki Nagano, Masaya HaraKawa, and Toshiyuki Kanmachi, *Member, IEEE*, "High-Performance Speed Servo System Considering Voltage Saturation of a Vector-Controlled Induction Motor," *IEEE Transaction On Industrial Electronics*, Vol. 53, No. 3, pp. 795-802, June 2006.
- [2] Dave Ross, John Theys, "Using the dsPIC30F for Vector Control of an ACIM," *Microchip Technology, USA*, AN908, pp. 1-76, 2004.
- [3] B. Plunkett, "A Current Controlled PWM Transistor Inverted Drive," *Conf. Rec. IEEE-IAS Ann. Meeting*, 1979, pp. 785-792.
- [4] H. Le-Huy, K. Slimani, and P. Viarouge, "Analysis and Implementation of a Real-time Predictive Controller for Permanent-magnet Synchronous Servo Drives," *IEEE Trans. On Ind. Elec.*, Vol. 7, No. 3, pp. 551-559, July 1992.
- [5] Xie Yue, *Member, IEEE*, D. Mahinda Vilathgamuwa, *Senior Member, IEEE*, "Robust Adaptive Control of a Three- Axis Motion Simulator With State Observers," *IEEE/ASME Transaction On Mechatronics*, Vol. 10, No. 4, pp. 437-448, August 2005.
- [6] D. C. Goodwin and K. S. Sin, *Adaptive Filtering Prediction and Control*, Prentice-Hall, 1984.
- [7] R. H. Middleton, and G. C. Goodwin, "Adaptive Control of time-varying Linear Systems," *IEEE Transaction On Automatic Control*, Vol. 33, No. 2, pp.150-155, February 1988.
- [8] Cheng-Jin Zhang, "Adaptive Induction Machine Current Control Using Internal Model Principle," *Proceeding of the 2004 American Control Conference Boston, Massachusetts*, pp.81-83 June 30-July 2, 2004.
- [9] Hoang Le-Huy, *Senior Member, IEEE*, and Louis A. Dessaint, "An Adaptive Current Control Scheme for PWM Synchronous Motor Drives: Analysis and Simulation," *IEEE, Transaction On Power Electronics*, Vol. 4, No. 4, October 1989.
- [10] Narendra, K. S., and Annaswamy, A. M. "Robust Adaptive Control In the Presence of Bounded disturbances," *IEEE Transaction On Automatic Control* 31:306-315, April 1986.
- [11] B. Plunkett, "A Current Controlled PWM Transistor Inverted Drive," *Conf. Rec. IEEE-IAS Ann. Meeting*, 1979, pp. 785-792.
- [12] Jorge Zambada, "Sensorless Field Oriented Control of PMSM Motors," *Microchip Technology, USA*, DS01078, pp. 1-27, 2007.